

**SUBDIVISION REGULATIONS
CHATHAM COUNTY, GEORGIA**

Recommended and Certified to the Commissioners of Chatham County and Ex-Officio Judges thereof by the Chatham County-Savannah Metropolitan Planning Commission at its regular meeting on the 13th day of June 1961.

Adopted by the Commissioners of Chatham County and Ex-Officio Judges Thereof, in Regular Meeting July 28, 1961.

(Amended Through March, 2004)

TABLE OF CONTENTS

	<u>Page</u>	
ARTICLE I	SHORT TITLE	1
ARTICLE II	ENACTMENT CLAUSE	1
ARTICLE III	JURISDICTION	1
ARTICLE IV	PURPOSES	1
ARTICLE V	SUBDIVISION DISTRICTS	2
	Section 500 - Subdivision Districts	2
	Section 501 - Subdivision District Map	2
ARTICLE VI	DESIGN STANDARDS	3
	Section 600 - Minimum Design Standards and Improvements	3
	Section 601 - Streets	3
	Section 601.02 - Design and Construction Specifications For Streets	6
	Section 601.02.1 - Right-of-way Requirements for Collectors, Major Arterials and Secondary Arterials	8
	Section 601.02.2 - Pavement Widths for Collectors, Major Arterials and Secondary Arterials	8
	Section 601.02.3 - Guidelines for Determining When Additional Widths are Needed for Collector and Arterial Roads	8
	Section 601.03 - Lanes	9
	Section 602 – Lots	9
	Section 602.01 - General Provisions	9
	Section 602.02 - Lot Width and Lot Area Requirements	10
	Section 602.03 - Building Lines	11
	Section 603 - Blocks	12
	Section 603.01 - Block Lengths	12
	Section 603.02 - Crosswalks	12
	Section 604 - Easement	12
	Section 604.01 - Utility Easements	12
	Section 604.02 - Drainage	12
	Section 604.03 - Maintenance Easement	12
	Section 605 - Monuments	12
	Section 606 - Water Supply and Sanitary Sewerage	13

**TABLE OF CONTENTS
(CONTINUED)**

	<u>Page</u>
Section 606.01 – Public Water and Public Sewerage	13
Section 606.02 – Private Water and Private Sewerage	13
Section 606.03 – Publicly Owned Water and Sewer Systems	13
Section 607 – Benchmarks	13
Section 608 - Filling or Excavation of Marshlands; Construction of Bridges, Causeways or Walkways	13
Section 608.01 - Filling or Excavation of Marshlands Permitted	13
Section 608.02 - Development Requirements	14
Section 608.03 - Development Plan Requirements	15
Section 608.04 - Construction of Bridges or Causeways	16
Section 608.05 - Permits Required	16
Section 609 - Preservation of Noteworthy Features	17
Section 610 - Environmental Site Assessment (ESA)	17
ARTICLE VII ADMINISTRATION	18
Section 700 - Administrative Agency	18
Section 700.01 - Notice Required	18
Section 701 - Sketch Plan	18
Section 702 - Preliminary Plan	19
Section 702.01 - Plan Requirements	19
Section 702.01.1 - Existing Features	19
Section 702.01.2 - Proposed Design Features	20
Section 702.01.3 - Other Information	21
Section 702.02 - Filing of Preliminary Plan	23
Section 702.03 - Action on Preliminary Plan	23
Section 702.04 - When Preliminary Plan Approved, Work May Proceed	24
Section 702.05 - Time Limit on Preliminary Approval	24
Section 703 - Final Plat	24

**TABLE OF CONTENTS
(CONTINUED)**

	<u>Page</u>
Section 703.01 - Final Plat Requirements	24
Section 703.02 - Cross Sections and Profiles	26
Section 703.03 - Certification from County Health Department	26
Section 703.04 - Certificate from County Engineer	26
Section 703.05 - Filing the Final Plat	27
Section 703.06 - Action on Final Plat	27
Section 703.07 - Revision to Recorded Plat	28
Section 704 - Minor Subdivision	29
ARTICLE VIII	
MODIFICATIONS	30
Section 800 – Reserved	30
Section 801 – Waiver of Paving Requirements	30
Section 802 – Modification of Right-of-Way Requirements	30
Section 803 - Final Plat Approval Only	31
Section 804 - Variances	31
Section 805 - Private Streets	31
Section 805.01 - Intent	31
Section 805.02 - Procedure for Establishment of Private Streets	31
Section 805.03 - Development Standards for Private Streets	33
Illustration “A” – Graphic Minimum Dimensions: Private Cul-de-sacs	34
Section 806 - Private Pedestrian or Vehicular Access Easement	35
Section 806.01 - Intent	35
Section 806.02 - Procedure for Establishment of Private Access Easements	35
Section 806.03 - Design and Construction Standards - Private Vehicular Access Easements	37
Section 806.04 - Design and Construction Standards - Private Pedestrian Access Easements	37

**TABLE OF CONTENTS
(CONTINUED)**

	<u>Page</u>
	38
	38
	39
ARTICLE IX	PENALTIES 39
	39
	39
ARTICLE X	DEFINITION OF TERMS 40
	40
ARTICLE XI	AMENDMENTS 43
	43
ARTICLE XII	LEGAL STATUS PROVISIONS 44
	44
	44
	44

AN ORDINANCE ESTABLISHING MINIMUM DESIGN STANDARDS FOR THE SUBDIVIDING OF LAND INTO STREETS, ALLEYS, AND LOTS, DEFINING CERTAIN TERMS USED HEREIN; PROVIDING FOR THE METHOD OF ADMINISTRATION AND AMENDMENT, PROVIDING PENALTIES FOR VIOLATION; REPEALING CONFLICTING ORDINANCES; AND FOR OTHER PURPOSES.

ARTICLE I

SHORT TITLE

This Ordinance shall be known and may be cited as the ■Subdivision Regulations of Chatham County, Georgia.●

ARTICLE II

ENACTMENT CLAUSE

The Commissioners of Chatham County and Ex Officio Judges, pursuant to the authority conferred by the provisions of Georgia Laws, 1957 Vol. 1, page 420 and the amendments thereto as codified in chapter 69-12 of the Georgia Code, annotated, do ordain and enact into law the following Articles and Sections.

ARTICLE III

JURISDICTION

The jurisdiction of this Ordinance shall be all that unincorporated area within the limits of Chatham County.

ARTICLE IV

PURPOSES

The various Articles and Sections of the Ordinances are adopted for the following purposes, among others:

- a. To help conserve and protect the natural, economic, and scenic resources of Chatham County.
- b. To help prevent and reduce the traffic congestion and traffic hazards which result from narrow or poorly aligned streets, and which result from excessive entrance and exit points along major traffic arteries.

- c. To help eliminate the costly maintenance problems which develop when streets and lots are laid out without proper consideration being given to the drainage characteristics of the tract of land at the time that land is being subdivided into streets and lots.
- d. To help prevent the spread of urban blight and slums.
- e. To help insure that residential lots will be of such design, area, and width as will prevent health and sanitation problems from developing in those subdivisions with lots to be served by individual water supply and waste disposal systems.
- f. To help insure that all building lots will be accessible to fire fighting equipment, and other emergency and service vehicles.
- g. To help protect the investments of the buyers of subdivision lots.
- h. To help promote and protect the health, safety, prosperity, and welfare of the citizens of Chatham County, and for other purposes.

ARTICLE V

SUBDIVISION DISTRICTS

Section 500. Subdivision Districts: For the purpose of this Ordinance, there are hereby established within Chatham County two (2) Subdivision Districts identified as follows:

- a. Urban District
- b. Rural District

Section 501. Subdivision District Map: The location and boundaries of the two Subdivision Districts shall be as shown on a map entitled ■Subdivision District Map of Chatham County, Georgia,• dated July 28, 1961, and as said map may be amended subsequent to the adoption thereof; and said map is made a part of this Ordinance to the same extent as if the information set forth on said map was fully described and incorporated herein. The Subdivision District Map of Chatham County shall be on file in the office of the Clerk of the County Commissioners.

ARTICLE VI

DESIGN STANDARDS

Section 600. Minimum Design Standards and Improvements: In order that various purposes of this Ordinance may be accomplished, all subdivisions hereafter established shall be developed and improved in accordance with the minimum design standards set forth in this Article. Provided, those parcels recorded prior to the effective date of these regulations which abut an unopened road shall not be developed until such road or portion thereof has been opened and paved according to County specifications or as certified to be paved in accordance with Section 703.04(b) of the Subdivision Regulations of Chatham County. Final approval shall not be given a subdivision until all appropriate design standards have been met and until all appropriate required improvements have either been installed or an appropriate bond or certified check has been posted to secure the installation of such improvements.

Section 601. Streets: Except as hereinafter provided, all streets established in any subdivision shall comply with the following general provisions.

- a. Continuation of Existing Street Pattern: The arrangement of streets in a subdivision shall provide for the alignment with, or the continuation of, or the appropriate projection of existing principal streets in surrounding areas.
- b. Street Jogs: Street jogs, or centerline offsets in the horizontal alignment of streets across intersections of less than one hundred and fifty (150) feet shall be prohibited.
- c. Intersections: The centerline of no more than two (2) streets shall intersect at any one point. Streets shall be laid out so as to intersect as nearly as possible at right angles and no streets shall intersect any other street at less than sixty (60) degrees. Curbed streets shall have a minimum tangent of one hundred (100) feet at intersections.
- d. Streets Intersecting with Major Arterials and Secondary Arterials: New streets entrances on roads designated or classified as major arterials shall be not less than seventeen hundred (1,700) feet apart and new street entrances on roads designated or classified as secondary arterials shall be not less than five hundred (500) feet apart. Provided, however, that the Planning Commission may reduce these requirements whenever it determines that such action will not be contrary to the purposes of this Ordinance.
- e. Subdivisions on Arterial Streets: Where a subdivision abuts or contains an existing or proposed arterial street, the Planning Commission may require marginal access streets, reverse frontage with screen planting contained in a non-access reservation along the rear property line, deep lots with rear service lanes, or such other treatment as may be necessary for adequate protection of residential properties and to afford separation of through and local traffic.

- f. Minimum Curb and Street Radius: The lot line radius at intersecting streets shall be not less than twenty (20) feet. The centerline radius of all curvilinear streets shall be not less than seventy-five (75) feet.
- g. Permanent Dead-End Streets: Dead-end streets, designed to be such permanently, shall be provided at the closed end with a turnaround having an outside roadway diameter of not less than eighty (80) feet, and a right-of-way diameter of not less than one hundred (100) feet.
- h. Temporary Dead-End Streets: Temporary dead-end streets shall be provided with a temporary turnaround area which shall meet the requirements of the Planning Commission for design, maintenance, and removal.
- i. Half-Streets: Half-streets shall not be permitted within a subdivision.
- j. Interior Streets: Interior streets within subdivisions shall be so laid out and designed that their use by through traffic and speeding traffic will be discouraged.
- k. Street Names: All streets within a subdivision hereafter established shall be named. No name shall be used which will duplicate or be confused with existing street names.
- l. Additional Right-of-Way: A proposed subdivision that includes a platted street that does not conform to the minimum right-of-way requirements of this Ordinance shall provide for the dedication of additional right-of-way along either one or both sides of said street so that the minimum right-of-way required by this Ordinance can be established. If the proposed subdivision abuts only one side of said street, then a minimum of one-half of the required extra right-of-way shall be dedicated by such subdivision.

Provided, however, the MPC shall waive the dedication of such additional right-of-way based on a finding that the platted street in question is an opened and paved street and the lotting arrangement and lotting development pattern along the street is unlikely to occur except under exceptional circumstances and therefore the opportunities to acquire right-of-way through subdivision approval is limited. Provided further, in the case of minor subdivisions, the MPC Staff, upon a favorable recommendation from the County Engineer, may approve such variances. However, where the future widening of the street will be required based on existing or future traffic projection, the MPC shall, as a condition of subdivision approval, require an additional building setback line from such street equal to one-half of the additional right-of-way that will be needed for the future widening of the street. Such setback requirement shall be in addition to the required setback lines established along the street. The following special notation shall be placed on the plat: ■No buildings, or required parking, or other permanent structures shall be placed within the required setback line.”

- m. Street Access to Adjoining Property: Whenever the Metropolitan Planning Commission finds that street access to adjoining property is needed, a street right-of-way shall be extended to the boundary of such property and such right-of-way shall be dedicated to the public as an unopened street. When such unopened street is required for access to property, then the developer of the property for which access is required shall be responsible for opening and improving the unopened street.
- n. Street Name Markers: Street name markers which shall be constructed to County specifications shall be installed at all street intersections.
- o. Major Thoroughfare Plan: When the Major Thoroughfare Plan of the community shows proposed arterial streets and collector streets within a proposed subdivision, the subdivider shall design the street system within such subdivision to conform with the location and arrangement of such arterial streets and collector streets.
- p. Sidewalks:
 - 1. Where Located: Sidewalks shall be provided along both sides of all streets within new subdivisions, and along the sides of existing streets which abut all new subdivisions, pursuant to the following provisions; provided that streets within the following types of subdivisions are exempt from this requirement:
 - a. Industrial developments and Planned commercial office parks where significant pedestrian traffic is unlikely.
 - b. Minor subdivisions not part of a series of subdivisions being created from a single tract or multiple tracts under a single ownership, and where no sidewalks are located within 350 feet along the same block face or contiguous block faces.
 - c. Recombination subdivisions when the total number of lots is not being increased.

Sidewalks shall be located within the street right-of-way, at least one foot from the property line and at least two feet from the back of the curb or the edge of the street pavement when there is no curb. Sidewalks shall be installed pursuant to Section 601.02(12).

The Metropolitan Planning Commission may approve a pedestrian path/modified sidewalk system upon a finding that said system would adequately serve the residents within the proposed subdivision and the general public.

2. Duty to Provide: The responsibility for providing required sidewalks shall be as follows:
- a. The building permit application for a lot within a subdivision hereafter approved shall install required sidewalks as provided for herein, or a pedestrian path/modified trail system when approved by the Planning Commission, along the applicants lot where it abuts Collector Streets, Minor or Residential Streets, and Marginal Access Roads, prior to the issuance of a Certificate of Occupancy.
 - b. The subdivider shall install sidewalks, as provided for herein, or a pedestrian path/modified trail system when approved by the Planning Commission, along all lots which abut a street classified as an Arterial; and wherever a subdivision street abuts common property or common area, along public lands (including where such streets cross drainage rights-of-way), and along utility sites, where they abut Major Arterials, Secondary Arterials, Collector Streets, Minor or Residential Streets and Marginal Access Roads, and when said system will not be located within the right-of-way of the abutting street, prior to final inspection (excluding the warranty period) of the proposed subdivision by the County Engineer.

601.02 Design and Construction Specifications for Streets: Except as hereinafter provided, all streets established in any subdivision shall be designed and constructed in accordance with the following specifications:

601.02(a) Design Specifications for Streets: Except as hereinafter provided, where a major subdivision abuts on an unpaved street which does not meet the design requirements of this chapter, the subdivider shall cause the street to be upgraded to meet the right-of-way, drainage and surface condition requirements of this chapter.

601.02 Design Specifications For Streets

List of Specifications	Type of Street				
	Major Arterial	Secondary Arterial	Collector Street	Minor Street	Marginal Access
1. Minimum Right-of-Way	See Sec. 601.02.1	See Sec. 601.02.1	See Sec. 601.02.1	60.ft.	40 ft.
2. Curb and Gutter a. Urban District	Shall be installed when feasible. Feasibility shall be determined by County Engineer.				
3. Width of shoulders (ditches)	8 ft.	8 ft.	8 ft.	8 ft.	8 ft.
4. Back Slope (curb and gutter)	8 ft.	8 ft.	8 ft.	8 ft.	8 ft.
5. a. Maximum slope of shoulders or back slope	1 in/ft.	1 in/ft.	1 in/ft.	1 in/ft.	1 in/ft.
5. b. Minimum slope of should or back slope	. in/ft.	. in/ft.	. in/ft.	. in/ft.	. in/ft.
6. Pavement width	36 ft. See	36 ft. Section	36 ft. 601.02.2	26. Ft.	20 ft.
7. Percent sub-base compaction, modified proctor	95%	95%	95%	95%	95%
8. Type of paving (minimum) a. Urban District	Asphalt or concrete installed to County specifications.				
b. Rural District	Unpaved but graded and ditched to County specifications.				
9. Distance between reverse curves	100 ft.	100 ft.	100 ft.	100 ft.	100 ft.
10. Minimum street centerline elevation	7.5 ft.	7.5 ft.	7.5 ft.	7.5 ft.	7.5 ft.

601.02 Design Specifications For Streets (Cont.)

List of Specifications	Type of Street				
	Major Arterial	Secondary Arterial	Collector Street	Minor Street	Marginal Access
11. Drainage	To be approved by County Engineer. Additional right-of-way for roadside ditches may be required when needed. In addition, all new subdivisions and all expansions of old subdivision shall be provided with drainage structures sufficient to accommodate a ten (10) year storm with immediate run-off; with out-fall drainage and structures sufficient to accommodate a fifty (50) year storm flood.				
12. Sidewalks a. Single-Family Residential	4 ft./4 in. P.C.C.	4 ft./4 in. P.C.C.	4 ft./4 in. P.C.C.	NOT REQUIRED	
Multi-Family Residential	6 ft./4 in. P.C.C.	6 ft./4 in. P.C.C.	6 ft./4 in. P.C.C.	6 ft./4 in. P.C.C.	6 ft./4 in. P.C.C. (one side)
Commercial	8 ft./4 in. P.C.C.	8 ft./4 in. P.C.C.	8 ft./4 in. P.C.C.	8 ft./4 in. P.C.C.	8 ft./4 in. P.C.C. (one side)
	Portland Cement Concrete				

- 601.02.1 Right-of-way Requirements for Collectors, Major Arterials and Secondary Arterials: In the case of collectors, major arterials and secondary arterials, the developer of land creating such street shall only be required to dedicate a seventy (70) foot right-of-way. If the governing body shall determine, pursuant to Section 601.02.3, that additional right-of-way is required for such streets, then the governing body shall negotiate with the developer for such additional right-of-way.
- 601.02.2 Pavement Widths for Collectors, Major Arterials and Secondary Arterials: If the governing body shall determine, pursuant to Section 601.02.3, that a pavement width of greater than thirty-six feet is required for collectors, major arterials and secondary arterials, then such governing body shall be responsible for providing such additional pavement.
- 601.02.3 Guidelines for Determining when Additional Widths are needed for Collector and Arterial Roads: When, in the opinion of the County

Engineer, a road or portion of road within a subdivision qualifies for classification as a Collector or Arterial Street, the developer shall provide a traffic study which estimates the average daily traffic volume for such road or portion thereof at maximum development.

When, in opinion of the County Engineer, the road in question will serve an area larger than the subdivision in question, traffic study area boundaries shall be extended to encompass such larger area.

Where the traffic study estimates that the average daily traffic volume will exceed 2,500 vehicles per day, the County Engineer may recommend to the governing body a pavement width in excess of 36 feet and a right-of-way width in excess of 70 feet.

601.03 Lanes: Lanes shall be provided in commercial and industrial districts, except that the Planning Commission may waive this requirement where other definite and assured provision is made for service access, such as off-street loading, unloading, and parking consistent with and adequate for the uses proposed. Such lanes shall conform to the following specifications:

- a. The width of a lane shall be twenty (20) feet.
- b. Dead-end lanes shall be avoided where possible, but if unavoidable a dead-end lane shall be provided with a turnaround having a diameter of not less than eighty (80) feet.

Section 602. Lots: All lots which shall hereafter be established within a subdivision shall comply with the following design standards.

602.01 General Provisions: The following general requirements shall apply to all lots hereafter established within a subdivision.

- a. Street Access: Each lot shall abut on a street which shall be dedicated as a public street and which conforms to the design requirements of this Ordinance; provided the Metropolitan Planning Commission and the Chatham County Commission may approve a residential, commercial and/or industrial lot which does not abut a public street but which is served by a perpetual privately maintained access easement which meets the design and construction standards of this Ordinance.

- b. Lot Lines: Side lot lines shall be as nearly as practical at right angles to straight street lines and radial to curved street lines.
- c. Corner Lots: Corner lots for residential use shall be provided with sufficient width and depth to permit the establishment of appropriate building setback lines from both streets.
- d. Double Frontage Lots: Double Frontage lots shall only be permitted where it shall be found necessary to separate a development from Major arterials or to overcome specific disadvantages of topography and orientation.
- e. Minimum Lot Elevation: The ground level within the building area of a lot shall be a minimum of eight (8) feet above mean sea level. Such building area shall be of such size as will permit all land within twenty (20) feet of the front and rear of a building to be a minimum of eight (8) feet above mean sea level. This minimum ground level may be increased by the Health Department or the County Engineer. The entire lot shall be properly drained. In addition to the foregoing, no lot shall be approve that does not contain a suitable building site of sufficient elevation to permit construction utilizing the first floor elevation at least the level of the 100-year flood.
- f. Residential subdivision lots shall be prohibited within flood plain areas where the cost of providing governmental services to the area would pose an unreasonable economic burden.

602.02 Lot Width and Lot Area Requirements: Lots hereafter established within subdivisions shall conform to the lot area and lot width requirements set forth in the following schedule, provided, however, that if a zoning ordinance is in effect, then the lot area and lot width requirements for the zoning district in which the subdivision will be located shall apply when such requirements are more restrictive than as set forth in subsection 1 and 2. The ■required• lot area shall be exclusive of areas delineated as Wetlands by the U.S. Corps Engineers, shall abut the approved access for said lot, and shall be of a uniform contiguous shape which complies with the minimum standards of the Subdivision and Zoning Regulations pertaining to lot area, lot width, and required setback lines, provided, however, the Metropolitan Planning Commission may approve a proposed lot which does not meet the minimum

standards upon a finding that the substandard lot being proposed will adequately accommodate the intended use and purpose without adversely impacting the prospective property owner, the adjoining properties, or Chatham County.

1. Residential Lots:

Condition Residential Lots	Minimum Lot Width at Front Building Line (in feet)*	Minimum Area (square feet)
1. Public water supply and public sewers	As set forth in the Chatham County Zoning Regulations	As set forth in the Chatham County Zoning Regulations
2. Public water supply and private sewers	As approved by the Chatham County Health Department as required by Georgia Department of Human Resources ■Manual for On-Site Sewage Management Systems•	
3. Private water supply and private sewers	As approved by the Chatham County Health Department as required by Georgia Department of Human Resources ■Manual for On-Site Sewage Management Systems•	

*The minimum lot width of all single family detached lots located along a permanent turnaround or along a *horizontal curve with a degree of curvature of 74 or more (this equates to the outside of a road curvature 100 degrees or less)* may be reduced up to 20 percent provided that the front yard building setback line shall be located on the lot at a point where the lot meets or exceeds the minimum required lot width.

2. Commercial and Industrial Lots: Depth and width of lots to be laid out or reserved for industrial and commercial purposes shall be adequate for the type of development contemplated and adequate to provide off-street parking and loading and service facilities.
3. Well Sites: Water wells for new water systems that provide piped water to the public for human consumption and have at least 15 service connections or regularly serve an average of 25 individuals daily at least 60 days out of the year shall be established on separate lots of record that shall be a minimum of 50 feet in depth and 50 feet in width. The minimum area of such lots shall be 2,500 square feet. Such lots shall be established only with direct access onto a public street or be served by a publically approved private vehicular access easement not less than 20 feet in width. Activities permitted on such lots shall be limited to those activities directly related to construction, operation, or maintenance of a well.

602.03 Building Lines: Building lines shall be provided on all lots hereafter established and shall conform to the requirements set forth in the Chatham County Zoning Regulations.

Section 603. Blocks: All blocks hereafter established within a subdivision shall conform to the following design standards.

603.01 Block Lengths: In order that there may be convenient access between various parts of a subdivision and between the subdivision and surrounding areas and in order to help prevent traffic congestion and traffic hazards, the length of blocks hereafter established shall not exceed eighteen hundred (1,800) feet.

603.02 Crosswalks: Rights-of-way for pedestrian crosswalks shall be provided when in the opinion of the Planning Commission crosswalks are necessary to give a direct pedestrian approach to schools, local shopping centers, and parks. Said rights-of-way shall not be less than ten (10) feet in width.

Section 604. Easements: The following kinds of easements shall be required within subdivisions:

604.01 Utility Easements: Public utility easements shall be provided where necessary. Such easements shall be not less than fifteen (15) feet in width and shall be centered on side or rear property lines when possible.

The location, elevation and construction of all public utilities and facilities, such as sewer, gas, electrical and water systems and streets, shall be in such a manner as to minimize or eliminate damage by flooding.

604.02 Drainage: Where a subdivision is traversed by a water course, drainage way, channel, or stream, there shall be provided a storm water easement or drainage right-of-way which shall conform substantially with the lines of such water course, drainage way, channel, or stream or shall be of such additional width or construction, or both, as will be adequate for the purpose.

604.03 Maintenance Easement: Where a drainage canal is such size that it requires mechanical means for cleaning, such as a dragline, there shall be a twelve (12) foot access easement on either side of such canal for access purposes.

Section 605. Monuments: The subdivider shall provide stone or concrete monuments four (4) inches in diameter or square, thirty (30) inches long, with a flat top, which shall be set at each street corner, and at all points where the street lines intersect the exterior boundaries of the subdivision, and at angle points and points of curvature in each street. The top of the monument shall contain a metal pin or be scored with an indented cross to properly identify the location. The subdivider shall also provide all

interior lot corners of subdivisions with concrete monuments, iron pins, or surveyors tacks imbedded in wooden stakes composed of pressure-treated timber not less than two (2) inches, by two (2) inches, by none (1) foot in length.

- Section 606. Water Supply and Sanitary Sewerage; Water and sewerage facilities shall conform to the following requirements:
- 606.01 Public Water and Public Sewers: When feasible every portion of a subdivision shall be served by public water; when feasible, every portion of a subdivision shall be served by a sanitary sewer system. All such systems shall be designed to preclude infiltration of flood waters into the system and discharges from the system into flood waters.
- 606.02 Private Water and Private Sewerage: Where either public water or public sewers or both are not available to a subdivision and a subdivider shall decide to establish a private water supply system and a private sewer system, then the plans and specifications for such private water system and sewer system shall be approved by the Chatham County Health Department. Any such private system shall be so located as to avoid impairment of them, or contamination from them, during times of flooding.
- 606.03 Publicly Owned Water and Sewer Systems: Water and sewer systems must be constructed in accordance with Chatham County Water and Sewer Department Specifications; sewer systems must connect to an existing publicly owned treatment plant, where practical, and both water and sewer systems and trunk lines shall be conveyed to an appropriate unit of local government for operation and maintenance.
- Section 607. Benchmarks: At least two (2) benchmarks shall be established within a subdivision. Such benchmarks shall be at opposite corners of the property being subdivided.
- Section 608. Filling or Excavation of Marshland; Construction of Bridges, Causeways or Walkways.
- 608.01 Filling or Excavation of Marshlands Permitted. Marshland may be excavated or filled to permit establishment of uses and structures permitted by the Chatham County Zoning Ordinance, subject to the following stipulations:
- A .All uses and structures established on marshlands shall be designed to assure the free flow of tidal water or storm drainage and avoid harmful impoundment.

- B. When use of fill material is found to be acceptable to the establishment of any land use, the County Engineer shall determine if the composition, placement, retention and limits or extent of such fill provide minimum practicable impediment to the free flow of tidal water or storm drainage and provide minimum immediate or potential adverse public effects.
- C. Approved fill material may include, but not be limited to, concrete rubble, bricks, gravel, sand, soil, or other suitable materials as approved by the County Engineer.
- D. Garbage, tree stumps, auto bodies, scrap lumber, paper or similar decomposable or putrescible materials shall not be approved as fill material for building sites, causeways, or walkways, but may be approved by the County Engineer for filling purposes where building sites are not created.
 - 1. Building permits shall be issued for improvements and developments which conform to the approved development plan.
- E. When a development plan for marshland dredging or filling, or construction of bridges, causeways or walkways is approved by the Metropolitan Planning Commission, it shall be so certified to the County Zoning Administrator.
 - 1. A note shall be placed on all land development plans or subdivision plats for areas filled with waste materials not approved for building sites, stating that limitation on future use.

608.02 Development Requirements.

Marshland excavation or filling may be permitted if:

- A. The proposed excavation or filling is necessary for uses permitted in the zoning district in which the proposed use is to be located.
- B. Engineering studies, soil samples, borings or other studies which may be required by the County Engineer indicate that any proposed filling is engineeringly and otherwise feasible and that the proposed fill material is satisfactory.
- C. Any filling, excavation or encroachment of a navigable stream is approved by the U.S. Army Corps of Engineers.

- D. The proposed project is presented on a land subdivision plat that has been approved by the Chatham County-Savannah Metropolitan Planning Commission, if the property created or affected by filling or excavation is to be subdivided into two (2) or more lots, building sites, or other divisions for the purpose of immediate or future sale, or involves the construction of a new street or a change in existing streets; or
- E. The project is presented on a land development plan or plat that has been approved by the Chatham County-Savannah Metropolitan Planning Commission, if the property created or affected by the filling or excavation is not to be subdivided, does not involve construction of a new street or a change in existing streets; provided:
 - 1. The Chatham County Engineer shall be authorized to review and approve land development plans where the property created or affect by the filling or excavation is less than then thousand (10,000) square feet in area.
 - 2. The County Engineer may require formal review of any development plan by the Metropolitan Planning commission, when such plan affects any area of less than ten thousand (10,000) square feet, where it is apparent that such area is immediately adjacent or abutting a similar area which has been approved under Section 608.02, E., 1, above, and where circumstances indicate that the purposes and intent of this ordinance may be subverted unless such review is accomplished.

608.03 Development Plan Requirements.

- A. An original copy and six (6) prints of the proposed project drawn at a scale of not less than two hundred (200) feet to the inch showing the following information:
 - 1. North arrow, date, name of property owner;
 - 2. Bearings and distances of the boundary lines of the property on which the proposed project is to be located;

3. The location of any streams, natural drainageways, channels, or other waterways which exist on the property;
4. Approximate existing elevation of the property to be filled or excavated, shown at one (1) foot contour intervals represented by solid lines on the plan, and based on Mean Sea Level datum;
5. Proposed final elevation of the property after filling or excavation, shown at one (1) foot contour intervals, represented by dashed lines on the plan, and based on Mean Sea Level datum.

608.04 Construction of Bridges or Causeways

- A. A bridge or piers, a causeway, or a walkway with any essential bridge or other structure to permit the free flow of tidal or other waters or, if required, the passage of water craft, may be constructed across marshland or constructed to connect an island with a mainland, or with another island, provided:
 1. Any crossing of any navigable stream shall be approved by the U.S. Army Corps of Engineers.
 2. All plans and specifications of any proposed bridge, causeway or walkway shall be approved by the County Engineer prior to construction.
 3. All completed bridges, causeways, or walkways shall be inspected and approved by the County Engineer prior to use.
 4. All bridges, causeways or walkways shall be equipped with culverts or other openings to assure the free flow of tidal water or storm drainage and to avoid harmful impoundment.

608.05 Permits Required

- A. A permit shall be required for any dredging or filling, or for any construction of bridges, causeways or walkways in marshland area affected by the general provisions of this ordinance.

- B. Such permits shall be issued by the County Zoning Administrator and shall be approved by the County Engineer prior to issuance.

Section 609. Preservation of Noteworthy Features

In all subdivisions, to the maximum degree reasonably practicable, efforts shall be made to preserve historic sites, scenic points, large trees and other desirable natural growths, watercourses and other water areas, and other features worthy of preservation, either as portions of public sites and open spaces, or in such other form as to provide amenity to the neighborhood.

1. Large trees or other desirable natural growths located in public or private street rights-of-way or public or private easements shall not be removed unless such removal is necessary for the installation of utilities or drainage structures or for other purposes in the public interests.
2. Such removal may be prohibited if the amenity of adjacent property, or the amenity of the general neighborhood is adversely affected.

Section 610. Environmental Site Assessment (ESA)

- A. Environmental Site Assessment Required. All applications for Final Subdivision Plat approval except as set forth herein, shall be accompanied by an ESA for the property in question. The ESA shall conform to the standards and requirements set forth for such reviews in the Chatham County Engineering Policy adopted by the Chatham County Commission.

The County Engineer is authorized to waive proposed minor subdivisions from the Subdivision Ordinance Environmental Site Assessment requirements unless there is a reasonable suspicion that a landfill or other environmentally dangerous situation exists.

No final subdivision requiring an ESA shall be approved until the ESA has been reviewed and approved by the County Engineer. Until such approval is given, no plat shall be recorded and no development within the proposed subdivision shall occur.

- B. Exceptions: An ESA shall not be required for subdivisions wherein: (a) all proposed lots are already developed and built upon: (b) the subdivision involves only a recombination of previously platted lots: or (c) the subdivision is a minor revision to a recorded plat.
- C. Reviews for Large Tracts of Land. Where a subdivision involves a large tract of land and is to be developed in phases, the Master Plan submittal for the entire tract shall not require an ESA. The Final Plat(s) shall be accompanied by an ESA.

ARTICLE VII

ADMINISTRATION

- Section 700. Administrative Agency: The Chatham County-Savannah Metropolitan Commission shall administer this Ordinance. It shall be the duty of the Planning Commission to inspect Sketch Plans and to suggest changes which should be made in the proposed design of a subdivision to insure the approval of the Preliminary Plan. It shall be the duty of the Planning Commission to inspect Preliminary Plans and to approve or disapprove such Plans. It shall be the duty of the Planning Commission to inspect Final Plats and the information submitted with such Final Plats, and recommend approval of such Final Plats when requirements of this Ordinance have been met and to recommend disapproval of such Final Plats when the requirements of this Ordinance have not been met. When the Planning Commission acts on the Final Plat it shall forward it to the County Commissioners and Ex Officio Judges Thereof with its recommendations.
- 700.01 Notice Required: The names and addresses of the owners of all properties abutting a tract or parcel of land for which a subdivision plat or land development plan or plat is required shall be submitted with such plat or plan. The Clerk of the Chatham County Commission shall notify said abutting property owners of the date, time and place of any public hearing at which said subdivision plat or land development plan or plat will be reviewed by the Chatham County Commission.
- Section 701. Sketch Plan: Previous to the filing of an application for approval of a Preliminary Plan, a Sketch Plan may be submitted to the staff of the Metropolitan Planning Commission for review. When submitted, a Sketch Plan shall show in simple sketch form the

proposed layout of streets, roads, lots and other features in relation to existing conditions. Except for large subdivisions (as determined by Staff) which shall be a scaled drawing, the sketch plan may be a freehand pencil sketch made directly on white bond paper. Sketch plans shall include the following: (a) The boundary lines of the property being subdivided; (b) Water courses and marshes found on the tract of the land to be subdivided and the limits of habitable area; (c) The location, name and right-of-way width of any existing streets on the land to be subdivided, or on land adjacent to the tract of land being subdivided; (d) The location of all improvements on the site to be subdivided.

Section 702. Preliminary Plan: Before work shall begin to open a subdivision, an original and eight (8) prints of a Preliminary Plan, showing the proposed design of the subdivision, shall first be submitted to the Metropolitan Planning Commission for approval. Until the Preliminary Plan of the proposed subdivision has been approved by the Metropolitan Planning Commission, a developer shall not grade, scrape, or otherwise open or extend a street in the proposed subdivision, nor shall he stake out or lay out lots in such subdivision, nor shall he in any manner cause construction to actually begin on a subdivision.

702.01 Plan Requirements: The original copy of the Preliminary Plan shall be drawn on transparent tracing paper with either black ink or soft pencil. Such Plan shall be drawn at a scale of not less than two hundred (200) feet to the inch. The Preliminary plan shall contain the following information:

702.01.1 Existing Features:

- a. The bearings and distances of the boundary lines of the property to be subdivided.
- b. The location of any streams, natural drainageways, and other waterways which exist on the property.
- c. When in the urban district, the distance and direction to public water lines and sanitary sewer lines.
- d. The name, location, and right-of-way width of existing streets eight on the property or on the land adjoining the property.
- e. Existing contours of the property in solid lines and at one foot intervals and based on Mean Sea Level datum.

- f. The name of subdivision or property owners adjoining the property.
- g. The location of railroads, of public or private rights-of-way or easements, and of parks or other public spaces either on the property or adjoining the property.
- h. All areas delineated as wetlands by the United States Army Corps of Engineers or Wetlands Consultant and/or areas established as Conservation Easements by the United States Army Corps of Engineers.
- i. Existing parcel identification numbers (PINs) for all properties located within the proposed subdivision.

702.01.2 Proposed Design Features

- a. The location, purpose, and width of any proposed drainage or utility easements.
- b. Lot lines and lot line dimensions; proposed lot numbers and block numbers.
- c. The location and specifications for proposed streets and lanes, including right-of-way lines, proposed paving, proposed finished grades, proposed pavement width, if any; profiles and typical cross-sections of such streets, and such other information as shall be required to show compliance with the design specifications established by this Ordinance for streets.
- d. Proposed street names.
- e. All plans shall show the expected limits of the 100-year flood in such a manner as to clearly show all lots and portions of lots which may be subject to flooding. Proposed final contours shall be shown in a solid line at one-foot intervals and shall be based on mean sea level datum.
- f. Proposed building lines.
- g. Proposed crosswalks.
- h. The location of proposed monuments and street name signs.

- i. Public use requirements. In layout of proposed subdivisions, subdividers shall give due consideration to the master plan showing thoroughfares, road classifications, sites for schools, playgrounds, playfields, parks, and other open spaces.

702.01.3 Other Information

- a. Name of proposed subdivision, scale of the plat, north arrow, date, size of the tract being subdivided, key map showing location of the proposed subdivision in the County.
- b. A statement from the subdivider shall be submitted with the Preliminary Plan which shall describe the method by which storm sewers, sanitary sewers, and water facilities will be provided. If septic tanks or individual waste disposal systems are to be used in a subdivision, then soil classification and percolation tests shall be made in accordance with County Health Department requirements; and the results of such test, together with a contour map showing the site of each test hole, shall accompany the Preliminary Plan.

Grading and drainage plans shall be submitted with each subdivision application. Hydraulic studies to evaluate the total effect of development will have on existing drainage facilities or streams shall be submitted by the developer when required by the County Engineer. Such studies shall generally be required when the additional runoff for the development will be two (2) cubic feet per second or greater, or where the development will increase the 100-year flood level upstream by more than 0.1 foot, or where a major drainage structure is required provided that these requirements may be increased by the County Engineer where deemed appropriate.

The grading and drainage plans shall be approved by the County Engineer and by the Planning Commission to insure conformance with all applicable requirements of this Ordinance and other County Code provisions. If the required drainage plans reveal that a requests for subdivision approval would overload the capacity of the channel downstream or increase flood stages upstream, the subdivision approval permit shall be denied, unless equivalent flow and storage capacity is replaced and maintained by the owner within the flood plain drainage easement.

Upon approval of the drainage plan by the County Engineer, the following drainage review form shall be submitted to the MPC prior to the meeting for which the proposed subdivision is to be heard by the Planning Commission:

DRAINAGE REVIEW/ACTION FORM

Name of Subdivision or Site Plan

The drainage plan for the above subdivision has been designed to meet the requirements of County Subdivision Regulations, the County Land Disturbing Activities Ordinance, and the County Engineering Policy, where applicable. Specifically, the drainage structures are sufficient to accommodate a 10 year storm with (immediate runoff), and the outfall drainage is sufficient to accommodate a 50 year storm. The post-development 50 year storm runoff has been limited to the predevelopment conditions, unless waived due to unrestricted outfall to tidal waterways. The County Engineer reserves the right to require revisions to the drainage plan as needed upon review of the full construction plans. Following MPC approval of the preliminary plan, the approved drainage plan will be on file at the County Engineer's Office.

CERTIFIED BY:

County Engineer or County Civil Engineer II

Date

Based upon the information supplied by the developer (and his registered professional engineer in Georgia) no exceptions have been noted by:

- c. When the Preliminary Plan includes only a part of the tract on which the subdivider has an interest, the developer shall submit a tentative street plan for all of said tract.
- d. All exhibits accompanying the Preliminary Plan shall be prepared by a registered Civil Engineer and shall contain the seal of such Engineer.
- e. Reserved.

- f. When the grading and drainage plan and/or construction plans contain all the required elements of the preliminary plan, such grading and drainage plan and/or construction plan may be submitted in lieu of a separate preliminary plan.

702.02 Filing of Preliminary Plan: The Preliminary Plan shall be filed with the Planning Commission not less than twenty (20) days prior to the regular Planning Commission meeting at which it is to be considered.

702.03 Action on Preliminary Plan: If the Planning Commission finds that the proposed design of the subdivision shown on the Preliminary Plan complies with the design requirements of these regulations, it shall approve such Preliminary Plan. Where the MPC finds that an established single-family residential area possesses an unique historical development pattern based on earlier development standards, and that the unique character of the area should be preserved and enhanced, the MPC may deny a proposed subdivision located within or visually related to such area when its proposed lots and/or general design do not reflect the character, size or arrangement of the established development pattern or that the proposed subdivision is not otherwise compatible with the established visual character of the area. If the Planning Commission finds that the proposed design of the subdivision shown on the Preliminary Plan does not comply with the design requirements of these regulations, then the Planning Commission shall either disapprove such Plan or shall approve such Plan on the condition that specified violations are corrected prior to the submittal of the Final Plat. When the Planning Commission disapproves a Preliminary Plan, it shall give the developer the reasons for such disapproval in writing. Except where an extension of time is authorized by the applicant for Preliminary Plan review, the Planning Commission shall have thirty (30) days from the date of the submission of a Preliminary Plan to act on such Plan. Unless action is taken on an application for Preliminary Plan review within the thirty (30) day period, the Preliminary Plan shall be deemed approved and a certificate of approval shall be issued by the Planning Commission on the demand of the applicant. The Planning Commission shall furnish the applicant for Preliminary Plat approval a copy of its decision within five (5) days after the meeting at which such Plan was acted on.

702.04 When Preliminary Plan Approved, Work May Proceed: When a developer receives approval of the Preliminary Plan showing the design of his proposed subdivision, he may proceed with the construction of the subdivision. Such construction shall conform with the design submitted to and approved by the Planning Commission.

702.05 Time Limit on Preliminary Approval: The Planning Commission's approval of a Preliminary Plan shall be valid for one (1) year. If work has not started on a subdivision which has been granted Preliminary Plan approval on or before the end of this one (1) year period, then the Plan of such subdivision shall be resubmitted for preliminary approval; provided, however, that this time may be extended unless changes have occurred in this Ordinance, or in the character of the property surrounding the property of the proposed subdivision which makes it necessary to revise the design of the proposed subdivision.

Section 703. Final Plat: Before a plat of subdivision is recorded with the Clerk of Superior Court of Chatham County and the lots thereon offered for sale, an original and eight (8) prints of a Final Plat showing the final design of the subdivision shall be submitted to the Metropolitan Planning Commission for review. A digital drawing of the Final Plat shall also be provided to the Metropolitan Planning Commission. Until a Final Plat of a subdivision has been submitted to and reviewed by the Metropolitan Planning Commission and approved and signed by the County Commissioners and Ex Officio Judges of Chatham County, the Clerk of the Superior Court of Chatham County shall not record the Plat of such subdivision, nor shall the owner or agent of such subdivision be authorized to transfer or sell any of the land within such subdivision by reference to a plat. For large subdivisions the Final Plat may be submitted for approval progressively in contiguous sections satisfactory to the Planning Commission.

703.01 Final Plat Requirements: The original copy of the Final Plat shall be drawn on eighteen inch by twenty-four inch (18" x 24") sheets of mylar or other material having equal properties, with black ink at a scale of not less than two hundred (200) feet to the inch. Where necessary, the Final Plat may be several sheets accompanied by an index sheet showing the entire subdivision. The digital drawing submittal shall meet the standards in the Digital Data Submission Standards set forth in the Chatham County Engineering Policy. The Final Plat shall contain the following information:

- (1) Primary control points to which all dimensions, angles, bearings, and similar data on the plat shall be referred.

- (2) Tract boundary lines; right-of-way lines of streets; easements and other rights-of-way; property lines of all lots; and in all such case with surveyed dimensions. Bearings or deflection angles, radii, arcs, and central angles of all curves shown.
- (3) Name and right-of-way width of each street or other right-of-way.
- (4) Location, dimensions, and purpose of any easement.
- (5) Number to identify each lot or site.
- (6) Purpose for which sites, other than residential lots, are dedicated or reserved.
- (7) Minimum building setback line on all lots and other sites.
- (8) Location and identification of monuments.
- (9) Names of record owners of adjoining unplatted land.
- (10) Reference to recorded subdivision plats of adjoining platted land by record name.
- (11) Certificate that all survey work was performed by a registered Civil Engineer or registered Surveyor.
- (12) Statement by owner, on the plat, dedicating streets, rights-of-way, easements, and any sites for public use. This statement shall be signed by the owner, or his attorney as agent, and shall read as follows:

All streets, rights-of-way, easements, and any sites for public use as noted on this plat are hereby dedicated for the use intended.

(Owner or Attorney as Agent)

Such dedications must be formally and specifically accepted by the Commissioners of Chatham County and Ex Officio Judges Thereof before such dedications shall be binding on the County.

- (13) Title, scale, north arrow, and date.
- (14) Key map showing the location of the subdivision in the County.
- (15) All Plats shall show the expected limits of the one hundred (100) year flood where appropriate.
- (16) When the Final Plat includes a proposed subdivision for which the developer intends to apply for either federally assisted or federally insured housing developments, then the developer shall simultaneously submit with his preliminary plat information required for the Planning Commission to carry out an A-95 review of the proposed development, unless such has been submitted previously with the preliminary plan.
- (17) All property use restrictions, including but not limited to Conservation Easements and Restrictive Covenants, imposed by Federal or State of Georgia agencies.
- (18) All areas established as Conservation Easements and areas delineated by the United States Corps of Engineers as wetlands, including wetlands which have been permitted for filling by the Corps.

703.02 Cross Sections and Profiles: The cross-sections and profiles of streets showing grades approved by the County Engineer shall accompany the Final Plat. The profiles shall be drawn to County standard scales and elevations and shall be based on Mean Sea Level.

703.03 Certification from County Health Department: If lots are not to be served by either public sewers or public water, or both, then the Final Plat shall be accompanied by a certificate from the County Health Department certifying Health Department approval of the water supply system and/or waste disposal system to be used and Health Department approval of lot sizes and lot widths established in such subdivision.

703.04 Certificate from County Engineer: At the time the Final Plat is submitted, it shall be accompanied by a certificate from the County Engineer certifying that the subdivider has complied with both of the following conditions:

- a. All improvements have been installed in accord with the requirements of this Ordinance and in accord with the design approved by the Planning Commission on the Preliminary Plan; and
- b. A construction bond, escrow account or certified check has been posted, which is available to the County, and in sufficient amount to assure the completion of all required improvements, as well as to assure the maintenance thereof for a period of not less than twelve (12) months after completion. The Commissioners of Chatham County, upon recommendation of the County Engineer, may reduce the bond or escrow account 50% upon completion of construction. If no faults or failures develop, the remaining bond or escrow may be reduced an additional 50% at the end of six (6) months. At the end of the second six (6) months, the developer shall request an inspection, and if no faults or failures have developed, the County Commission shall release the bond or escrow. Construction bonds or escrow shall remain in force until released by the Chatham County Commissioners after due inspection of said improvements and shall not automatically expire at the end of twelve (12) months. Maintenance bonds or escrow shall automatically expire at the end of twelve (12) months from the date of completion of construction.

703.05 Filing the Final Plat: The Final Plat shall be filed with the Planning Commission not less than twenty (20) days prior to a regular meeting of the Planning Commission.

703.06 Action on Final Plat: If the Planning Commission finds that all the requirements of this Ordinance have been met, it shall recommend approval of the Final Plat and submit such Plat to the Commissioner of Chatham County and Ex Officio Judges. Where the MPC finds that an established single-family residential area possess an unique historical development pattern based on earlier development standards, and that the unique character of the area should be preserved and enhanced, the MPC may deny a proposed subdivision located within or visually related to such area when its proposed lots and/or general design do not reflect the character, size or arrangement of the established development pattern or that the proposed subdivision is not otherwise compatible with the established visual character of the area. If the Planning Commission finds that all the requirements of this Ordinance have

not been met, and after deficiencies have been discussed and reviewed with the sponsor, and the sponsor given a period of time which shall not exceed ninety (90) days to take corrective action, then the Planning Commission shall recommend disapproval of the Final Plat to the County Commissioners and shall set forth its reasons for such recommendations in writing. Except where an extension of time is authorized by the applicant for Final Plat review, the Planning Commission shall have thirty days (30) from the date of the submission of a Final Plat to submit its recommendations on such plat to the Commissioners of Chatham County. Unless such action is taken within such thirty (30) day period, then such plat shall be deemed to have received a recommendation for approval from the Planning Commission and the Commissioners of Chatham County may take final action on such plat without waiting further for the recommendations of the Planning Commission.

- a. When the Final Plat has been approved, the Planning Commission shall present the Final Plat to the Clerk of the Superior Court of Chatham County, Georgia, to be recorded. The Planning Commission shall provide the subdivider with the subdivision map book number and page number in which the subdivision has been recorded by the Clerk of Superior Court. The cost of such recording shall be paid by the subdivider and shall be deposited with the Planning Commission prior to such recording.
- b. After the Final Plat of the subdivision has been recorded, then all lots shown on such subdivision may be made available for sale and such subdivision shall be entitled to all privileges and services available to other subdivisions within the County.

703.07 Revisions to Recorded Plat:

(a) Major Revisions.

The subdivider shall file with the Planning Commission copies of the proposed revision to a recorded plat together with all supporting information as required by these regulations. Proposed revisions to a recorded plat which alter or change in any way the street and/or utility layout of said plat shall be submitted as a preliminary plat in accordance with Section 702 of these regulations.

(b) Minor Revisions.

Proposed revisions to a recorded plat which do not alter or change in any way the street and/or utility layout of said plat shall be submitted as follows:

The subdivider shall file with the Planning Commission four (4) copies of the original plat with all minor revisions shown in red. The plats shall be accompanied by a statement signed by all affected property owners acknowledging their awareness of and approval of the revisions. Proposed revisions shall be reviewed by the MPC Staff and the County Engineer. Upon a finding that the revisions comply with all applicable regulations, the revised plats shall be signed by the MPC Executive Director, the County Engineer and the Clerk of Superior Court. One (1) copy of the revised plat shall be recorded and one (1) copy shall be attached to the originally recorded plat as part of the public record.

(c) Recombinations.

The combination or recombination of portions of previously platted lots where the total number of lots is not increased and the resultant lots are equal to the standards set forth in this Ordinance shall be processed as a minor subdivision as a forth in Section 704. - provided that a recombination of two (2) or more lots of record into one (1) lot shall be exempt from this Ordinance.

Section 704. Minor Subdivisions: Minor subdivisions may be submitted as Final Plats, and shall comply with the requirements of these regulations, including minimum finished floor elevation requirements and submittal of a digital drawing, with the following exceptions:

- a. Minor subdivisions shall not be required to have Metropolitan Planning Commission review unless so requested by the MPC Staff, other review agency or the developer. Minor subdivisions may be referred to the Planning Commission for processing as a major subdivision if requested by either the MPC Staff, other review agency, or the developer.
- b. Topographic information shall not be required, unless requested by the County Engineer.
- c. Percolation information shall not be required, unless requested by the Health Department.

- d. Only one (1) benchmark shall be required. An existing accessible benchmark within two hundred (200) feet of petitioner's property, if shown on the plat, shall satisfy this requirement.
- e. The developer shall submit a drainage plan for approval if requested by the County Engineer.
- f. Minor subdivision final plats shall be approved and signed by the MPC Executive Director, County Engineer, Chatham County Health Department, and the County Administrator. Minor subdivision final plats will not require review by the Chatham County Commission; provided that where lots are intended for or adaptable to further subdivision, or where a series of minor subdivisions are developed or proposed immediately adjacent to one another, the Planning Commission staff, or other review agency may require the developer to comply with the procedures for major subdivisions.

ARTICLE VIII

MODIFICATIONS

Section 800. Reserved.

Section 801. Waiver of Paving Requirements: Within the Urban District the paving requirements of this Ordinance shall be waived on request of the subdivider for a subdivision of four (4) lots or less which involves either the extension of an unpaved street or the opening of a new street, provided that such street extension or new street shall not exceed four hundred (400) feet in length, and shall end in a permanent dead-end or intersect another street. All land which abuts upon such street extension or new street shall be within the subdivision for which the waiver of paving is granted and shall not be subject to further subdividing.

Section 802. Modification of Right-of-Way Requirements: The street right-of-way requirements of this Ordinance shall be reduced on the request of the subdivider for a subdivision of four (4) lots or less which involves the extension of an existing street with a right-of-way width smaller than that required by this Ordinance or which involves the opening of a new street. Provided, however, that such street extension or new street shall not exceed four hundred (400) feet in length and shall end in a permanent dead-end or intersect another street. All land which abuts upon such street extension or new

street shall be within the subdivision for which the modification of the right-of-way width is granted and shall not be subject to further subdividing. In no case shall a right-of-way width be reduced to less than forty (40) feet.

Section 803. Final Plat Approval Only: In the case of a subdivision which shall have lots fronting only on an existing, open, and public street and which does not require a new street, the developer of such subdivision shall only be required to submit a Final Plat. The Planning Commission shall approve such Final Plat if it finds that the subdivision described thereon complies with all of the applicable requirements of this Ordinance.

Section 804. Variances: When a peculiar shape, or the topography of a tract of land, or other unusual condition makes it impractical for a developer to comply with the literal interpretations of the design requirements of this Ordinance, the Planning Commission shall be authorized to vary such requirements, provided, however, that in so doing the intents and purposes of this Ordinance are not violated.

Section 805. Private Streets

805.01 Intent: The intent of this section is to permit establishment of private streets or roads in subdivisions, where such private streets or roads are deemed appropriate. Private streets or roads may be appropriately established to help preserve the environment, aesthetic quality, or historical or natural aspects of a development site.

Private streets or roads shall only be permitted to be established:

- a. Where such private road development would not effectively subvert or negate the benefit to the general public intended to be created by application of the public street requirements of this Ordinance; and
- b. Where potential future development beyond the properties abutting the private road would not require use of the private road for traffic circulation.

805.02 Procedure for Establishment of Private Streets: Private streets may be established in accordance with Planned Unit Development procedures, or conventional subdivision procedures. The following minimum standards apply to private street proposals. Exceptions by a developer shall be processed in accordance with Planned Unit Development procedures.

- a. All design, grading, drainage and construction plans for all private streets or roads hereinafter established shall be prepared by a registered civil engineer.
 1. Construction supervision shall also be provided by the engineer responsible for preparing said plans.
- b. A notation shall be placed on all plats of any subdivision in which a private street or road is established stating that all maintenance of the right-of-way or road surface shall be the responsibility of abutting property owners only.
- c. The developer of any subdivision in which a private street or road is established shall provide the Chatham County Savannah Metropolitan Planning Commission and the Chatham County Commissioners with a maintenance agreement, consisting of covenants running with title to all lots abutting such private street, indicating that a third party such as a trust or fiduciary, agrees to assume the financial and legal responsibility for maintenance and operation of any such private street or road established.
- d. The developer and each subsequent owner shall notify the purchaser or every lot abutting a private street or road, in writing, that the responsibility of maintenance and operation of the private street or road and private drainage features such as canals, ditches, and swales, shall remain with abutting lot owners.
 1. Failure to notify each such lot purchaser shall constitute violation of this Ordinance.
- e. A private street or road may be dedicated to, and accepted by, Chatham County for public street purposes, provided such private street or road meets the minimum design and construction requirements for public streets of Chatham County.
- f. The maintenance or improvement of the right-of-way or pavement surface of any private street hereinafter established shall not be assumed by Chatham County unless such street meets the minimum standards for public streets of the County; provided that upon application of fifty-one percent (51%) of the owners of frontage property abutting any private street, or upon a finding by the County Engineer that essential access for public purposes is or is about to be dangerously impeded or hindered, the County may make necessary street or roadway improvements or

repairs, install storm drainage systems, or make other necessary improvements and shall assess all costs to benefited abutting properties based on a ratio of current tax valuation. Such costs shall become and remain a lien on said properties until paid.

- g. The developer shall install and maintain signs along private street rights-of-way which read: ■Private Street - Not County Maintained.
 - 1. Such sign shall be installed at intersections of public and private streets.
- h. All governmental agencies shall have right of entry to, and right of passage on, any private street, hereinafter established, for the purposes of providing necessary public services to the residents or owners of areas served by such private streets.

805.03 Development Standards for Private Streets: All private streets shall conform to the following standards and specifications.

Street Classification	Minimum Right-of-Way Width Required	Minimum Roadway Width Required	Minimum Paving, Curb and Gutter, Sidewalk Roadside Drainage and Roadside Shoulder Requirements
Collector	60'	26' with curb and gutter or 24' with 8' shoulders and ditches	All materials and construction standards shall meet minimum requirements for public streets.
Minor or Residential (serving 12 to 24 dwelling units)	40' plus additional ROW, if necessary	24' paving (min. 25' base with vertical curbs or equal)	
Minor or Residential (serving 12 or less)	30' plus additional ROW, if necessary	20' paving with center drainage or inverted crown	
Cul-de-sac - circular - ■T. or ■Y. type	All private cul-de-sacs shall meet the minimum dimensions shown on Illustration ■A. - Graphic Minimum Dimensions: Private Cul-de-sacs		

ILLUSTRATION "A"

GRAPHIC MINIMUM DIMENSIONS PRIVATE STREETS

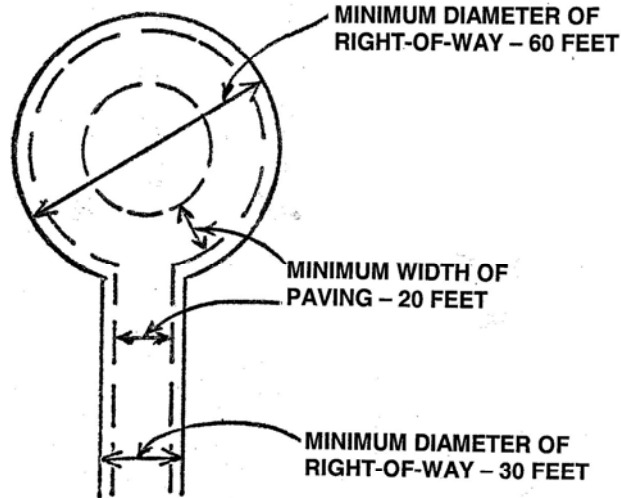

MINIMUM DIMENSIONS OF CIRCULAR CUL-DE-SACS

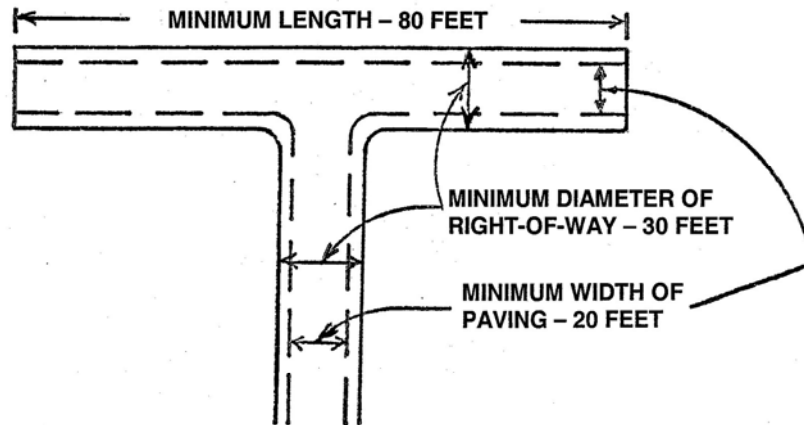

MINIMUM DIMENSIONS OF "T" OR "Y" CUL-DE-SACS

Section 806. Private Pedestrian or Vehicular Access Easements

806.01 Intent: The intent of this section is to permit establishment of private pedestrian or vehicular access easements in residential, commercial and industrial subdivisions, where such access easements are deemed appropriate. Private access easements may be appropriately established to encourage innovative land development techniques and to enhance the convenience and ease of access to new developments.

806.02 Procedure for Establishment of Private Access Easements

Private pedestrian or vehicular access easements may be established in accordance with Planned Unit Developments procedures, or conventional subdivision procedures. The following minimum standards apply to private access easement proposals. Exceptions requested by developers shall be processed in accordance with Planned Unit Development procedures.

- a. All design, grading drainage and construction plans for all private access easements hereinafter established shall be prepared by a registered civil engineer, and approved by the County Engineer.
 1. Construction supervision shall also be provided by the engineer responsible for preparing said plans or by a resident engineer or inspector on the job full time.
- b. A notation shall be placed on all plats of any subdivision in which a private access easement is established stating that all maintenance of the right-of-way and road surface shall be the responsibility of abutting property owners only.
- c. The developer of any subdivision in which a private access easement is established shall provide the Chatham County-Savannah Metropolitan Planning Commission and the Chatham County Commission with a maintenance agreement, consisting of covenants running with title to all lots abutting such private easements, indicating that a third party such as a trust or fiduciary, agrees to assume the financial and legal responsibility for maintenance and operation of any such private access easement established

- d. The developer shall also notify the purchaser of every lot abutting a private access easement, in writing, that the responsibility of maintenance and operation of the easement and private drainage features, such as canals, ditches and swales shall remain with abutting lot owners.
 - 1. Failure to adequately notify each abutting lot owner shall constitute violation of this Ordinance.
- e. A private access easement may be dedicated to, and accepted by, Chatham County for public street purposes, provided such access easement meets the minimum design and construction requirements for public streets of Chatham County.
- f. The maintenance or improvements of the right-of-way or pavement surface or any private easement hereinafter established shall not be assumed by Chatham County unless such easement or extensions of existing right-of-way meets the minimum standards for public streets of the County; provided that upon application of fifty-one percent (51%) of owners of frontage property abutting any private access easement or upon a finding by the County Engineer that essential access for public purposes is or is about to be dangerously impeded or hindered, the County may make necessary paving improvement or repairs, install storm drainage systems, or make other necessary improvements and shall access all costs to benefited abutting properties based on a ratio of current tax valuation. Such costs shall become and remain a lien on said properties until paid.
- g. The developer shall install and maintain signs along private access easement rights-of-way which read: ■Private Access Easement - Not County Maintained.●
 - 1. Signs shall be installed at all intersections of public streets and private access easements.
- h. All governmental agencies shall have right of entry to, and right of passage on, any private access easement hereinafter established, for the purpose of providing necessary public services to the residents or owners of areas served by such private access easement.

806.03 Design and Construction Standards - Private Vehicular Access Easements

Minimum width of access easement:	Minimum paving and drainage requirements:
22 feet*	1. Minimum pavement width 18 feet;**
	2. Paving and drainage plans to be approved by County Engineer
Maximum length of easement:	Maximum number of units to be served:
750 feet	6
<p>*No parking shall be allowed on the easement unless the right-of-way width is increased, and no parking space shall be designed or constructed to permit backing onto the easement, or other direct access to the vehicular easement, except via a driveway approved by the Metropolitan Planning Commission and the Chatham County Commission.</p> <p>**The driving surface of a private vehicular access easement serving only three or fewer single family residential lots, may be unpaved but shall be constructed to minimum specifications as required by the County Engineer.</p>	

806.04 Design and Construction Standards - Private Pedestrian Access Easements

Minimum right-of-way:	Minimum paving, drainage, planting and grading requirements:
5 feet	1. Minimum improvements shall be required according to the function or intent of the pedestrian easement; provided that: <ul style="list-style-type: none"> a. Minimum sidewalk width shall be 4 feet; <ul style="list-style-type: none"> 1. All soils shall be stabilized with adequate planting or other materials to protect against erosion;
	2. Buffers or screening shall be established where required.

806.05 Additional Access Easements Required

Whenever a proposed access easement is determined by the County Engineer and the Metropolitan Planning Commission to be inadequate to accommodate necessary utilities, drainage, traffic or maintenance operations, additional abutting or parallel easements for these purposes shall be required by said Commission to dimensions specified by the County Subdivision Regulations.

807. Establishment of Private Common Open Spaces or Areas Permitted

Private common open spaces or areas may be permitted to be established as part of a conventional subdivision or planned unit development approved by the Metropolitan Planning Commission and the Chatham County Commission, provided that the establishment of such open spaces or areas are deemed appropriate and provided the following minimum requirements are met:

- a. Basic and final grading and drainage plans of all private common open spaces or areas hereinafter established as part of a subdivision or planned unit development shall be approved by the County Engineer.
- b. A notation shall be placed on all plats of any subdivision or planned unit development in which private common open spaces or areas are established stating that all maintenance of the open spaces or areas shall be the responsibility of abutting property owners only.
- c. The developer of any subdivision or planned unit development in which private open spaces or areas are established shall provide the Chatham County-Savannah Metropolitan Planning Commission and the Chatham County Commission with a satisfactory maintenance agreement, consisting of covenants running with title to lots in the subdivision or planned unit development, indicating that a third party such as a trust of fiduciary has agreed to assume the financial and legal responsibility for maintenance and operation of any such private common open space or area established which has not been dedicated to and accepted by Chatham County.

- d. The developer shall also notify the purchaser of every lot in the subdivision or planned unit development, in writing, that the responsibility of maintenance and operation of private common open spaces or areas shall remain with abutting lot owners. Failure of the developer to adequately notify each abutting lot owner shall constitute violation of this Ordinance.
- e. Private open spaces or areas may be dedicated to, and may be accepted by, the Chatham County Commission, provided that the title and physical conditions of such spaces or areas meet the minimum requirements of the County.
- f. All governmental agencies shall have right of entry to, and right of passage on, any private open space hereinafter established, for the purpose of providing necessary public services to the residents or owners of areas served by such private open space.

808. Establishment of Public Common Open Spaces

Public common open spaces may be established as part of a new residential subdivision where a Homeowners Association is not proposed, provided that the land area of the entire subdivision is established by Chatham County as an Open Space Assessment District prior to recording the final plat pursuant to the requirements of the Chatham County Open Space Assessment Ordinance.

ARTICLE IX

PENALTIES

Section 900. Violation a Misdemeanor: Any person violating any provision of this Ordinance shall, upon conviction, be deemed guilty of a misdemeanor and shall be subject to such penalties as are provided by law for other misdemeanors.

Section 901. Other Penalties: Unless a subdivision hereafter established shall be designed, developed, and recorded in accordance with the provisions of this Ordinance, then:

- a. The County shall not accept the dedication of any street within such subdivision, nor shall the County improve, maintain, grade, pave, or light any street within such subdivision unless such street or streets shall have received the status of public streets prior to the adoption of this Ordinance.

- b. The County shall not assume any responsibility for drainage problems within such subdivision unless County owned and maintained drainage structures already exist in such subdivisions.
- c. The County shall not issue a building permit within such subdivision.
- d. No unit of local government shall be authorized to extend any publicly operated service or utility into such subdivision.

ARTICLE X

DEFINITION OF TERMS

Section 1000. Definitions: For the purpose of this Ordinance, certain words or terms used herein shall be defined as follows:

- 1. Interpretation of Words: Words used in the present tense include the future tense. Words used in the singular number include the plural, and words used in the plural include the singular.
- 2. District, Rural: Unincorporated areas of Chatham County where limited growth is anticipated. This may be due to economic, geographic or topographic features and/or inaccessibility. Because of low densities and the absence of many urban problems, stringent development standards are not appropriate.
- 3. District, Urban: Unincorporated areas of Chatham County developed wholly or in part where extensive growth is anticipated. Because of high densities and the presence of many urban problems, stringent development standards are appropriate.
- 4. Person: The word "person" includes a firm, corporation or copartnership.
- 5. Shall: The word "shall" is always mandatory and not merely directory.
- 6. Lot: A portion of a subdivision intended as a unit for transfer or for development, or both. The word "lot" includes the word "plot" or "parcel."

7. Lot Width: The distance between the side lot lines measured at the building line.
8. Sewerage, Public: A system that is owned, maintained and operated by the County, a municipality, or a community corporation or a privately owners system serving a community and approved by the Chatham County Health Department.
9. Street: A way for vehicular traffic which affords the principal means of access to abutting property.
10. Streets, Arterials: Those streets which are designated as arterials on the major thoroughfare plan and which are used or intended primarily for fast or heavy traffic.
11. Streets, Collector: Those streets which carry traffic from minor streets to the major system of arterial streets and highways, including the principal entrance streets of a residential development and streets for circulation within such a development.
12. Streets, Minor: Those streets which are used primarily for access to abutting properties.
13. Streets, Marginal Access: Those minor streets which are parallel to and adjacent to arterial streets and highways; and which provide access to abutting properties, and protection from through traffic.
14. Streets, Lanes: Minor ways which are used primarily for vehicular service access to the back or the side of properties otherwise abutting on a street.
15. Subdivision: All divisions of a tract or parcel of land into two or more lots, building sites, or other divisions for the purpose of immediate or future sale, legacy, or building development. All divisions of land involving a new street or a change in existing streets. The term includes the resubdivision of land and when appropriate to the context relates to the process of subdivision or to the land subdivided.
- 15a. Minor Subdivision: Any subdivision comprising three lots or less and not involving a new street or change in an existing street.

- 15b. Major Subdivision: Any subdivision comprising four lots or more, or any subdivision involving a new street or change in an existing street.
16. Water, Public: A system that is owned, maintained, and operated by the County, a municipality, or a community corporation, or a privately owned system serving a community and approved by the Chatham County Health Department.
17. Marshland: All land subject to tidal action which is comprised of general unstable soil materials commonly known as ■hard• or ■soft• marsh, which in its natural state is vegetated with marsh grass, reeds and similar growth, and is usually characterized by poor load-bearing capacity. Marshland lies below an elevation of six (6) feet above mean sea level in Chatham County.
18. Private Pedestrian or Vehicular Access Easements: A private pedestrian or vehicular access easement shall be defined as any pedestrian or vehicular access way, driveway, walkway, or other means of ingress or egress which is not dedicated to, or accepted by, Chatham County, and which is privately owned, operated and maintained.
19. Private Street: A private street shall be defined as any street or road which is platted, but not reserved or dedicated to, nor accepted by Chatham County and whose use is restricted by notice of sign, or by a gate, barrier, or other device intended to exclude the general public, or where such street is identified as ■private• on a recorded subdivision plat.
20. Street, Opened: A street shall be deemed to be opened if it is either of the following:
- (a) available for public use prior to the adoption of this Ordinance, or
 - (b) was constructed to County specifications following the adoption of this ordinance.
21. Street, Unopened: A street or any part thereof, shall be deemed to be unopened if it is not cleared, graded and available for public use.

22. Environmental Site Assessment: An assessment by a professional engineer or other licensed professional experienced in geotechnical investigations and the assessing of real property for environmental concerns, to determine the likelihood of the presence of a landfill or other environmentally dangerous situations on a site, according to procedures set forth for such assessment in the Chatham County Engineering Policy.
23. Unique Historical Development Pattern: A land use pattern that is representative of earlier development practices that gives an area visual character that would not be achieved through the application of the minimum design standards of the Subdivision Regulations or development standards which would vary in character from the existing development pattern.
24. Visual Character: The composition of design features of an area including but not limited to size and arrangement of lots, the location and types of structures on lots, open spaces, tree cover, street pattern and walkways that sets an area apart from other development.
25. Visually Related: Development that can readily be seen from adjacent, or other nearby development.

ARTICLE XI

AMENDMENTS

- Section 1100. Amendment: This Ordinance may be amended from time to time, but no amendment shall become effective unless it shall have been proposed by or shall first have been submitted to the Chatham County-Metropolitan Planning Commission for review and recommendation. The Planning Commission shall submit its report within thirty (30) days after receiving an amendment proposal from the Commissioners of Chatham County and Ex Officio Judges Thereof, otherwise said amendment proposal shall be deemed approved by the Planning Commission. Before enacting an amendment to these regulations, the Commissioners of Chatham County and Ex Officio Judges Thereof shall hold a public hearing thereon, notice of which shall be published at least fifteen (15) days prior to such hearing in a newspaper of general circulation in Chatham County.

ARTICLE XII

LEGAL STATUS PROVISIONS

- Section 1200. Validity: Should any section or provision of this Ordinance be declared by the Courts to be unconstitutional or invalid, such declaration shall not affect the Ordinance as a whole, or any other part thereof other than the part so declared to be unconstitutional or invalid.
- Section 1201. Effective Date: This Ordinance shall take effect and be enforced from and after its adoption.
- Section 1202. Repeal of Conflicting Ordinance: All ordinances and parts of ordinances in conflict herewith are hereby repealed.